

# LEAK DETECTOR<sup>®</sup>

## Ensuring the integrity of every cheese block.

This advanced Leak Detector provides unsurpassed in-line leak detection of vacuum-sealed bags containing 20kg/44lb cheese blocks. Uniquely designed to meet customer needs, it provides an autonomous and reliable system to check for leaking vacuum in all sealed cheese blocks from the sealing machine.



## BENEFITS

- > Safeguards your brand reputation and elevates customer satisfaction by delivering consistent quality
- > Detects slack bags post-sealing and before wrap around casing, preventing mold in cheese store
- > Quick ROI delivery
  - Removes the need for labor after the vacuum sealer
  - Significantly cuts down the costs associated with returned product
- > Delivers the highest leak detection and lowest false rejection efficiency in the industry. Proven to be superior to camera based detection systems
- > Minimise waste or downgrading by capturing leaks early, allowing for:
  - 100% recovery of rejected blocks by rebagging and resealing
  - Detecting issues with gusseter and sealer

## Get in Touch

Contact us today to discuss your leak detection needs and to find out more:

**Email:** [info@pft.ie](mailto:info@pft.ie) | **Website:** [www.powerfoodtec.com](http://www.powerfoodtec.com)



# LEAK DETECTOR®

The leading Leak Detection solution for Cheese Block Producers

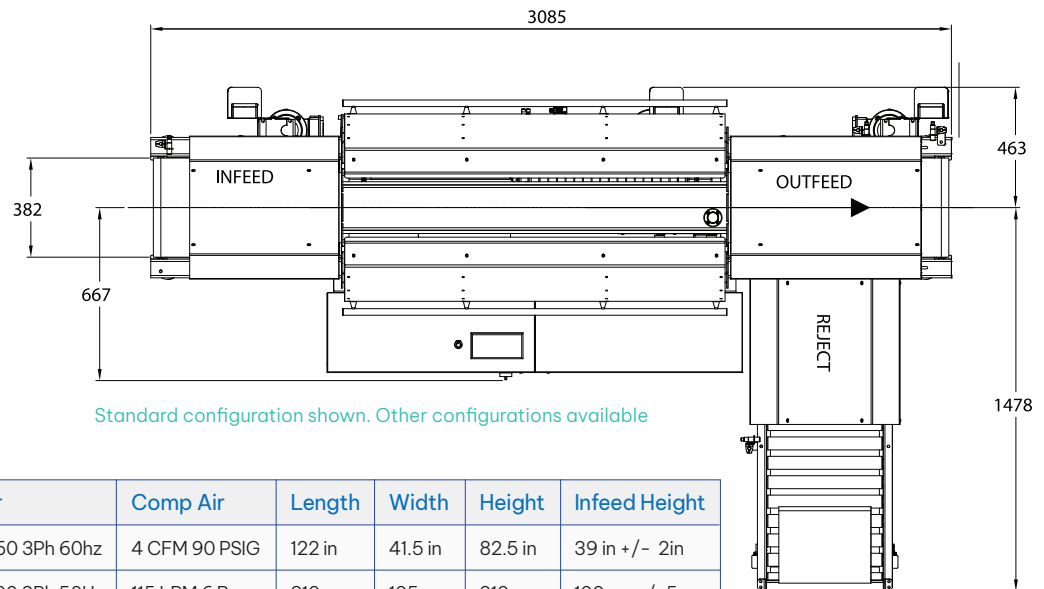

Model	Capacity	Power	Comp Air	Length	Width	Height	Infeed Height
USA	12 Blocks per minute	3kW 460 3Ph 60hz	4 CFM 90 PSIG	122 in	41.5 in	82.5 in	39 in +/- 2in
EU		3kW 400 3Ph 50Hz	115 LPM 6 Bar	310 cm	105 cm	210 cm	100cm +/-5cm

## FEATURES:

- > Easy to operate – power up and run
- > Continuous testing without stopping the block for highest capacity
- > Unique travelling head design achieves the longest leakage test time while the block is in motion
- > Automatically adjusts for block height variations
- > Cheese block handling is gentle at all times with zero risk of damage to bag or sealed gusset
- > Touchscreen-enabled programs for variable cheese types and firmness
- > Low maintenance and cost of ownership
- > Hygienically designed, suitable for dry cleaning and wipe-down
- > Integrated infeed and reject station, configurable to fit into the line
- > Dedicated PLC and motor control panel for seamless plant SCADA system integration
- > Detailed data on throughput, rejection rate and line efficiencies



## POWER FOOD TECHNOLOGY LTD

Site 1E, Clane Business Park  
Clane, Co. Kildare, Ireland  
Tel: +353 (45) 82 0081

10053 Simonson Road, Suite 3  
Harrison, Oh 45030, USA  
Tel. +1 (513) 401 8281

